

Reg. No. :

--	--	--	--	--	--	--	--	--	--	--	--	--	--	--	--	--	--	--	--

**Question Paper Code : 30200**

B.E./B.Tech. DEGREE EXAMINATIONS, APRIL/MAY 2023.

Second Semester

GE 3251 – ENGINEERING GRAPHICS

(Common to All Branches)

(Regulations 2021)

Time : Three hours

Maximum : 100 marks

(HMT data book may be permitted)

(Permitted : A3 sheet)

Answer ALL questions.

(5 × 20 = 100)

1. (a) The distance between the fixed point and a fixed line is 54 mm. Trace the path of a point moving in the same plane such that its distance between the fixed point and the fixed line is always equal. If the point moves upto 72 mm from the fixed point, plot the curve.

Or

- (b) A coin of 35 mm diameter rolls in a straight line on a table. Plot and name the locus of a point lying on the circumference of the coin.

2. (a) The distance between the projectors of two points A and B is 70 mm. A is 15 mm above the HP and 15 mm in front of VP. B is 50 mm above HP and 30 mm in front of VP. Find the shortest distance between A and B by rotating line method. Find the true inclination of AB with VP and HP.

Or

- (b) A thin rectangular plate of sides 60 mm × 40 mm has its shorter side in VP and inclined at 30° to HP. Project its top view, if its front view is a square of 40 mm side.

3. (a) A pentagonal prism of side 30 mm and axis 60 mm long, rests with one of its base edges on HP such that the base containing that edge makes an angle of  $35^\circ$  to VP and its axis is inclined at  $40^\circ$  to HP. Draw its projections.

Or

- (b) Draw the front view, top view and right side view of the 3D object given below.

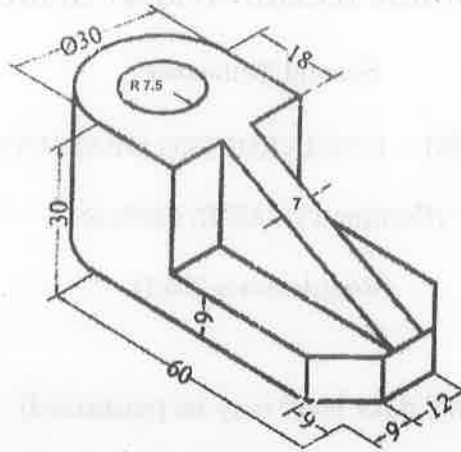

4. (a) A triangular prism with a base side of 45 mm and height 60 mm rests on its base on HP with a rectangular face perpendicular to VP. It is cut by an auxiliary inclined plane such that the true shape of the section is an isosceles triangle of maximum size. Draw its projection and true shape of section.

Or

- (b) A lamp shade is formed by cutting a cone of base 150 mm diameter and 180 mm height by a horizontal plane at a distance of 70 mm from the apex and another plane inclined at  $30^\circ$  to HP, passing through one extremity of the base. Draw the development.
5. (a) A cylinder 40 mm diameter and 60 mm height stand on HP with its base. A section plane perpendicular to VP, inclined at  $55^\circ$  to HP cuts the cylinder and passes through a point on the axis at a height of 45 mm above the base. Draw the isometric projection of the truncated portion of the cylinder, when the cut surface is clearly visible to the observer.

Or

- (b) A circular lamina of 50 mm diameter lies on the ground plane and touches the picture plane. The center plane passes through the center of the circle. Station point is 60 mm in front of picture and 70 mm above the ground plane. Draw the perspective projection.